

Overview

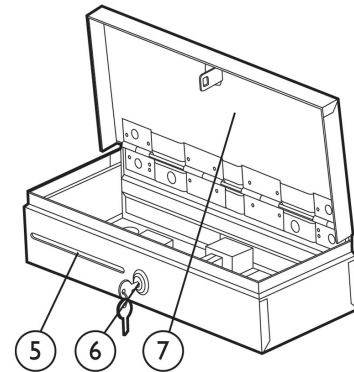
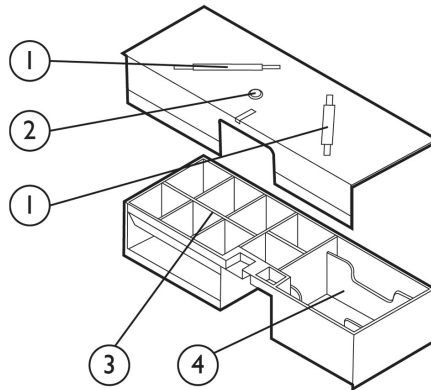

1. Till insert handles
2. Cover lock
3. Eight (8) coin slots
4. Adjustable bill slots

5. Media slot
6. Solenoid Lock
7. Stainless steel lid

Model

HP Flip-Top Cash Drawer

BW867AA

Introduction

Designed for seated store associate or space-constrained environments, the HP Flip-Top Cash Drawer provides a robust and stylish cash management solution. It features a heavy duty black case with a stainless steel lid that flips open for easy access from the top, which makes this model suitable for operation while seated or standing.

With a narrow depth, the HP Flip-Top Cash Drawer is designed to minimize the amount of counter space required in your retail environment. In fact, this model can be designed so that the top surface is used as counter space, until the cash drawer is opened.

The HP Flip-Top Cash Drawer comes with one universal till with adjustable bill slots with up to 6 slots and 8 coins cups. It also includes a lockable lid with handles. Keys are included for both the Cash Drawer and the till lid.

Key Benefits

- Space-saving design with 172mm (6.77") in depth that can maximize counter space
- Robust durable construction designed to sustain the typical wear of retail environments
- Universal till features adjustable bill dividers
- Locking till cover with handles allow for easy removal and transportation of the till insert
- HP POS printer interface cable for easy connection to one of the HP POS printers (can also be connected directly to the integrated cash drawer port on the HP Retail System)

Overview

Compatibility

The HP Flip-Top Cash Drawer is compatible with the HP Point of Sale Systems and HP POS printers. The cash drawer can be connected directly to the HP Retail System through the integrated cash drawer port. For all other HP Point of Sale Systems, the cash drawer must be connected via the provided interface cable through a HP POS printer.

NOTE: Not all HP Point of Sale System models or HP POS Printer models are available in all regions. Check with your HP Partner or Sales Representative for more information.

Third party printer models may require a 3rd party interface cable to operate with the HP Flip-Top Cash Drawer.

Service and Support

Your HP Peripheral Limited Warranty is a three (3) year (HP Option Limited Warranty Period) parts replacement warranty.

Technical Specifications

General

Construction	Black steel base with stainless steel lid
Media Storage	Single media slot provides storage for transactions
Lock	Cash drawer keyed alike, till cover randomly keyed
Till Insert	6 adjustable Bill dividers with 8 coin slots

Mechanical

Dimensions (LxWxH)	18.11 x 6.77 x 4.05 in (460 x 172 x 103 mm)
Till Dimensions	17.00 x 6.00 x 3.50 in (432 x 152 x 89 mm)
Weight	11.9 lbs (5.4 kg) with till and locking cover
Media Storage Slot	7.09 x 4.21 x 0.94 in (180 x 107 x 24 mm)
Operating Range	+0°C - +40°C (32°F - +104°F)

Interface/Connection

Cable	RJ45 from drawer to RJ12 (HP POS Printers)
Cable Length	10 ft (3.05 m)

Power

Operating Voltage	24V Solenoid
--------------------------	--------------

Operating Systems

Compatible with:	Genuine Windows 7 Business 64 Genuine Windows 7 Business 32 Genuine Windows Embedded POSReady 2009 Genuine Windows Embedded for Point of Service (WEPOS) Genuine Windows Vista® Business 32 Genuine Windows XP Professional 32
-------------------------	---

Reliability

Over 2,000,000 opening and closing cycles

Agency Certifications

CE

Option kit contents

Technical Specifications

HP Flip-Top Cash Drawer with set of 2 keys, adjustable till with locking cover with set of 2 keys, interface cable for the HP POS Printers, and HP Point of Sale System Software and Documentation CD and the Options Warranty Manual.

Additional Options

Spare HP Flip-Top Till Insert with Locking Cover (Part # BZ335AA)



HP Cable Pack for Dual Cash Drawers (Part # QT538AA)

© Copyright 2013 Hewlett-Packard Development Company, L.P. The information contained herein is subject to change without notice. The only warranties for HP products and services are set forth in the express warranty statements accompanying such products and services. Nothing herein should be construed as constituting an additional warranty. HP shall not be liable for technical or editorial errors or omissions contained herein. Microsoft, Windows, Windows XP and Windows Vista are trademarks of the Microsoft group of companies.